

Year 7 Maths 2025 – 2026

Topic 1 Algebra Conventions

Term	Definition	Try these
a	1a (we don't write 1 in algebra)	Write an expression that means... a) 6 more than x b) 6 less than x c) The sum of x and y d) The product of a and b e) a divided by b f) x multiplied by x g) Two lots of x
3a	3 lots of 'a'	
a + 3	3 more than 'a'	
a - 3	3 less than 'a'	
a ²	a x a a to the power 2	
$\frac{a}{3}$	a' divided by 3 or "a third of a" We don't use the ÷ symbol	

Forming Expressions

Anna is "x" years old. Carl is 2 years older than Anna. Eddie is twice as old as Anna. Write a simplified expression for their total age.				Anna is "x" years old. Carl is double Anna's age. Eddie is three years younger than Carl. Write a simplified expression for their total age.			
Anna	Carl	Eddie	Total	Anna	Carl	Eddie	Total
x	x + 2	2x	x + x + 2 + 2x 4x + 2	x	2x	2x - 3	x + 2x + 2x - 3 5x - 3

Topic 2 – Multiples, Factors, Squares and Primes

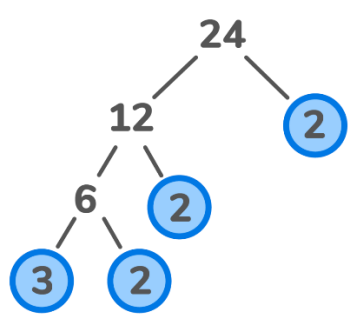
<u>Multiples</u>	<u>Squares</u>	<u>Factors</u>	<u>Primes</u>
A number that is in the times tables of another number. For example, 12 is a multiple of 4. List the first five multiples of 6: 6, 12, 18, 24, 30	The result when an integer is multiplied by itself. For example, 5 ² means 5 x 5 which is 25. 25 is the square number.	A number that divides into another number with no remainder. For example, 4 is a factor of 12. List the factors of 12 1 12 2 6 3 4	A number with exactly two factors, 1 and itself. 2, 3, 5, 7 11, 13, 17, 19 23, 29 <u>Writing as a product of prime factors</u>  $24 = 2 \times 2 \times 2 \times 3$ $24 = 2^3 \times 3$

Questions to try

- | | | | |
|--|--|--|---|
| <ul style="list-style-type: none"> Work out the fifth even multiple of 3 Find the lowest common multiple of 6 and 8 Write down all the odd multiples of 7 that are greater than 20 and less than 40 | <ul style="list-style-type: none"> Evaluate 8^2 Work out $6^2 - 3^2$ Write down the fourth square number Work out $\sqrt{49}$ | <ul style="list-style-type: none"> Find the highest common factor of 24 and 42 Work out the lowest common multiple of 12 and 16 Write down all the factors of 30 that are also multiples of 5 | <ul style="list-style-type: none"> Is 9 a prime number? Explain your answer. Find two prime numbers that sum to make a square number. Write 150 as a product of its prime factors in single index form |
|--|--|--|---|

Topic 3 - Operations with Fractions

Shading fractions

A fraction shows how many equal parts a whole has been split into.

Make sure the parts are all the same size

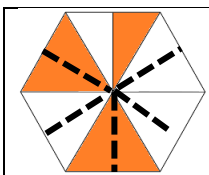

Add dotted lines
Count $\frac{5}{12}$

Worded and simplifying/equivalent

Make equivalent fraction by multiplying

$$\frac{18}{50} = \frac{36}{100}$$

x2

Simplify by dividing by HCF

$$\frac{6}{33} = \frac{2}{11}$$

÷3

Mixed Numbers and Improper Fractions

$\frac{7}{4}$ means $7 \div 4 \rightarrow$

Whole number \rightarrow 1 \leftarrow Numerator \leftarrow 3
Denominator \uparrow 4

$$3\frac{1}{5} = \frac{16}{5}$$

(5x3)+1=

Questions to try

<p>What fraction is shaded?</p> <p>What fraction is not shaded?</p>	<p>Out of a class of 24 pupils, 8 are vegetarian. What proportion of the class are not vegetarian? Give your answer in its simplest form.</p> <p>Which is bigger $\frac{6}{9}$ or $\frac{11}{18}$ You must show your working</p>	<p>Convert into mixed numbers (simplest form)</p> $\frac{13}{5} \quad \frac{13}{3} \quad \frac{30}{8}$ <p>Convert these into improper fractions</p> $2\frac{1}{5} \quad 5\frac{2}{3} \quad 6\frac{4}{6}$
---	---	--

<u>Multiplying Fractions</u>	<u>Dividing Fractions</u>	<u>Adding or Subtracting</u>
Does not need common denominator <ul style="list-style-type: none"> • Top x top • Bottom x bottom Cross-cancel if possible. Simplify result where possible. $\frac{1}{3} \times \frac{3}{5} = \frac{3}{15}$ $\frac{3}{15} = \frac{1}{5}$	Multiply by reciprocal. Use "Keep, Flip, Change" Keep the first fraction same. Flip the second fraction upside down (reciprocal). Change the ÷ to x. Multiply as normal. $\frac{1}{3} \div \frac{2}{5}$ $\frac{1}{3} \times \frac{5}{2} = \frac{5}{6}$	Need common denominator. Add or Subtract numerators. Denominator stays the same. $\frac{1}{3} + \frac{2}{5}$ $\begin{array}{r} \times 5 \\ \frac{5}{15} + \frac{6}{15} = \frac{11}{15} \end{array}$

Questions to try

$$\frac{2}{3} \times \frac{3}{4} \quad \frac{21}{30} \times \frac{15}{28} \quad \frac{2}{3} \div \frac{3}{4} \quad 5\frac{5}{6} \div 2\frac{3}{8} \quad \text{Find the product of } \frac{2}{5} \text{ and } \frac{10}{18}$$

Find the total of $\frac{3}{4}$ and $\frac{2}{3}$ Find the difference between $\frac{3}{4}$ and $2\frac{1}{3}$ $9\frac{1}{3} + 3\frac{1}{4}$

I cut a rope measuring $2\frac{1}{2}$ m into equal pieces that are each $\frac{1}{4}$ m. How many pieces will I make?

$\frac{2}{3}$ of a year group walk to school. Of those that walk to school $\frac{1}{4}$ walk with a sibling. What proportion of the year walk to school with a sibling?

<u>Fractions of amounts</u>	<u>Multi-step with fractions</u>	<u>Reverse Fractions</u>												
Q) Work out $\frac{2}{3}$ of 600g <table border="1" style="margin: 10px auto;"> <tr> <td>200</td> <td>200</td> <td>200</td> </tr> <tr> <td colspan="3" style="text-align: center;">600</td> </tr> </table> $600 \div 3 = 200$ $200 \times 2 = 400\text{g}$	200	200	200	600			Hayley gets £120 for her birthday. She spends $\frac{1}{3}$ on clothes. She spends $\frac{1}{4}$ of what is left on a meal. How much is leftover? $£120 \times \frac{1}{3} = £40$ $£120 - £40 = £80 \text{ left}$ $\frac{1}{4} \times £80 = £20$ $£80 - £20 = £60 \text{ left over}$	Q) $\frac{2}{3}$ of a number is 24. What was the number? <table border="1" style="margin: 10px auto;"> <tr> <td>12</td> <td>12</td> <td>12</td> </tr> <tr> <td colspan="3" style="text-align: center;">24</td> </tr> </table> $24 \div 2 = 12$ $12 \times 3 = 36$ The number was 36	12	12	12	24		
200	200	200												
600														
12	12	12												
24														

Questions to Try

Brad has 378 sweets.
 Brad gives $\frac{2}{9}$ of them to Will.
 How many does Will get?
 How many does Brad have left?

There are 900 pupils in a school.
 $\frac{2}{9}$ of them live within 2miles.
 Of those that live within 2 miles, $\frac{3}{4}$ walk to school.
 How many pupils walk to school?

$\frac{3}{4}$ of a number is 36.
 Work out what the number is.

Topic 4: Perimeter

Perimeter

Perimeter is the **distance around** a 2D shape. It is measured using units of *length* such as millimetres, centimetres, metres, and kilometres.

Perimeter of this shape is 12cm

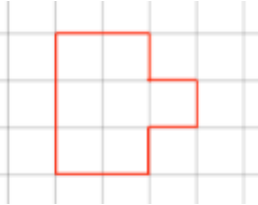

Perimeter of squares and rectangles

A **Square** has four equal sides

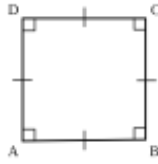

A **Rectangle** has 2 pairs of equal opposite sides

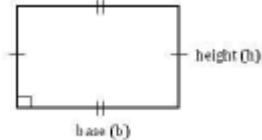

A **Parallelogram** has 2 pairs of equal opposite sides

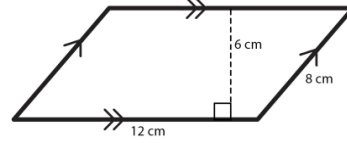

In example above

$$\text{Perimeter} = 12 + 8 + 12 + 8 = 40\text{cm}$$

Perimeter of triangle

A **Triangle** has three sides.
In an isosceles triangle, two of the sides are equal.

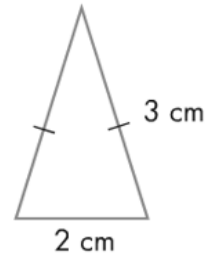

We copy the 3cm to the other side.

$$P = 2 + 3 + 3 = 8\text{cm}$$

Questions to try

Work out the perimeter of these shapes

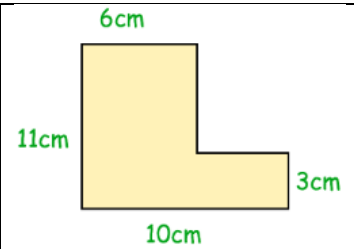
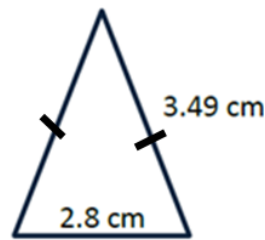
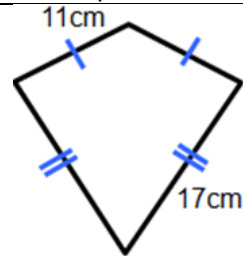
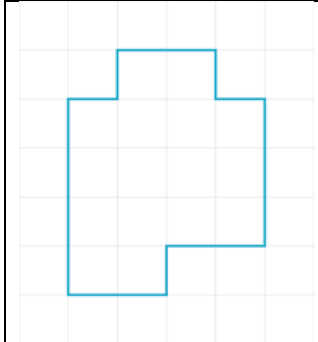

Perimeter of L Shape

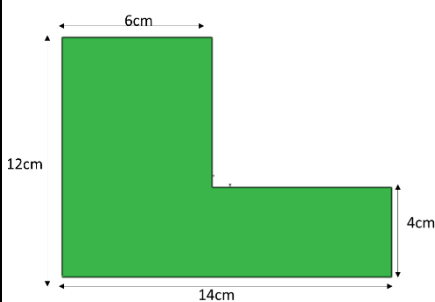

$$\text{Perimeter} = 12 + 14 + 4 + 8 + 8 + 6 = 52\text{cm}$$

Vertical lines

12	?
	4

Missing = 8cm

Horizontal

6	?
14	

Missing = 8cm

Finding missing sides

The perimeter of this triangle is 38cm.
Work out missing length "x"

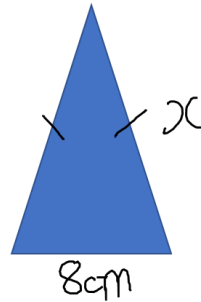

Copy the "x" to the other side

$$x + x + 8 = 38$$

$$2x + 8 = 38$$

$$- 8 \quad - 8$$

$$2x = 30$$

$$\div 2 \quad \div 2$$

$$x = 15$$

Topic 5 – Multiplying and Dividing by Powers of 10

Topic 5 – Multiplying and Dividing by Powers of 10			
<u>Multiplying by 10, 100, 1000</u>	<u>Dividing by 10, 100, 1000</u>	Using Powers $10^2, 10^3$	Negative powers (0.1, 0.01)
<p>Multiplying by 10 move the decimal one place to the right</p> <p style="text-align: center;">$48.2 \times 10 = 482$</p> <p>Multiplying by 100 move the decimal two places to the right</p> <p style="text-align: center;">$48.2 \times 100 = 4820$</p> <p>Multiplying by 1000 move the decimal three places to the right</p> <p style="text-align: center;">$48.2 \times 1000 = 48200$</p>	<p>Dividing by 10 move the decimal one place to the left</p> <p style="text-align: center;">$48.2 \div 10 = 4.82$</p> <p>Dividing by 100 move the decimal two places to the left</p> <p style="text-align: center;">$48.2 \div 100 = 0.482$</p> <p>Dividing by 1000 move the decimal three places to the left</p> <p style="text-align: center;">$48.2 \div 1000 = 0.0482$</p>	<p>$10^1 = 10$ $10^2 = 100$ $10^3 = 1000$</p> <p>We can use this short form to write sums such as</p> <p style="text-align: center;">5.04×10^3 means $5.04 \times 1000 = 5040$</p>	<p>$0.1 = 10^{-1}$ (because this is $\frac{1}{10}$) $0.01 = 10^{-2}$ (because this is $\frac{1}{10^2}$) Move the decimal point in the opposite direction to normal (i.e. $5.3 \times 0.1 = 0.53$ as decimal moves left once)</p>
<p>$0.45 \times 10 = \underline{\hspace{2cm}}$</p> <p>$5.6 \times 100 = \underline{\hspace{2cm}}$</p> <p>$\underline{\hspace{2cm}} = 4.05 \times 1000$</p> <p>$\underline{\hspace{2cm}} \times 10 = 62.3$</p> <p>Work out the number that is 100 times greater than 4.5</p> <p>Work out the number that is 100 greater than 4.5</p>	<p>$8524 \div 1000 = \underline{\hspace{2cm}}$</p> <p>$6.24 \div 10 = \underline{\hspace{2cm}}$</p> <p>$\underline{\hspace{2cm}} = 8306.4 \div 100$</p> <p>Work out the number that is 100 times smaller than 240.6</p> <p>Work out the number that is 100 smaller than 240.6</p>	<p>$53 \times 10^2 = \underline{\hspace{2cm}}$</p> <p>$\underline{\hspace{2cm}} = 4.5 \div 10^3$</p> <p>$0.503 \times 10^4 = \underline{\hspace{2cm}}$</p> <p>$642 \div 10^1 = \underline{\hspace{2cm}}$</p>	<p>$4.5 \div 10^{-3} = \underline{\hspace{2cm}}$</p> <p>$\underline{\hspace{2cm}} = 5.6 \times 10^{-2}$</p> <p>$\underline{\hspace{2cm}} \times 10^{-2} = 28.4$</p> <p>$\underline{\hspace{2cm}} \div 10^{-2} = 4.7$</p>

Topic 6 – Rounding and Recurring

Round to nearest <u>10/100/1000</u>	<u>Round to nearest integer</u>	<u>Round to 1 decimal place</u>	Round to 2 decimal places
1334 nearest 10 is 1330 1334 nearest 100 is 1300 1334 Nearest 1000 is 1000	59.926 to nearest integer is 60	59.926 to 1 decimal place is 59.9	59.926 to 2 decimal places is 59.93 Note: money is always rounded to 2dp so £18.5 = £18.50

Questions to try

Round 2465 to the nearest 10	Round 8.2 to the nearest integer	Round 8.45 to 1 decimal place	Round 6.4081 to 2 decimal places
Round 2465 to the nearest 100	Round 9.8 to the nearest integer	Round 61.82 to the nearest tenth	Round £6.497 to 2 decimal places
Round 2465 to the nearest 1000	Round 120.359 to the nearest integer	Round 89.08 to the nearest tenth	Round 456.852 to the nearest hundredth

<p><u>Working backwards</u></p> <p>I am thinking of a number. I round it to the nearest 10. My answer is 80. What is the largest integer I could have been thinking of?</p>	<p>I am thinking of a number. I round it to the nearest 100. My answer is 800. Work out the difference between the largest and smallest integers that I could have been thinking about.</p>
<p><u>Recurring Decimals</u></p> <p>Write $46 \div 3$ as a recurring decimal Use a bus-stop division Answer: $15.\dot{3}$</p>	<p>Write $40 \div 6$ as a recurring decimal</p> <p>Write $50 \div 3$ as a recurring decimal</p>

Topic 7: Percentages

Common Conversions

You must learn these common conversions between fractions, decimals and percentages

<u>Fraction</u>	<u>Percentage</u>	<u>Decimal</u>
$\frac{1}{2}$	50%	0.5
$\frac{1}{4}$	25%	0.25
$\frac{3}{4}$	75%	0.75
$\frac{1}{5}$	20%	0.2(0)
$\frac{1}{10}$	10%	0.1(0)
$\frac{1}{8}$	12.5%	0.125
$\frac{1}{3}$	33.3%	0.3̇
$\frac{2}{3}$	66.6%	0.6̇

Finding Basic Percentages

$10\% = \frac{1}{10}$ so to find 10% we divide by 10

e.g. Find 10% of £840

$$\frac{1}{10} \times £840 = 840 \div 10 = £84$$

We can use ratio/proportion to help

e.g. Find 10% of £52

%	Amount
100%	£52
÷ 10	÷ 10
10%	£5.20

Joe scored 4 out of 20 on a test, what was his percentage?

Ibrahim scored 12 out of 40 on a test, work out his percentage.

Justin scored 3 out of 8 on a test. Amy scored 40%. Who did better? You must show your working.

Expressing as Percentage

Form a fraction then convert to a percentage.

Factor of 100

If the denominator is a factor of 100 multiply it to make the denominator 100

$$\frac{3}{20} \times \frac{5}{5} = \frac{15}{100} = 15\%$$

Simplify to a factor of 100

If the denominator can be simplified to a factor of 100, do that first then multiply it to make the denominator 100

$$\frac{18}{60} = \frac{3}{10} \times \frac{10}{10} = \frac{30}{100} = 30\%$$

Decimal then Percentage (Bus stop division)

If neither of the above are possible and you don't know the equivalence (see table on left), then use "bus stop" division to convert to a decimal then x100

Finding any percentage using multiplication

We can find any percentage using the ARMS method

e.g. Find 35% of 450kg

Amount: 450kg

Rate: 35%

Multiplier: $\frac{35}{100} = 0.35$

Sum: $450 \times 0.35 = 157.50\text{kg}$

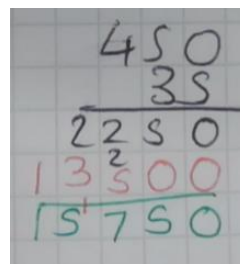

Work out

- 10% of £640
- 50% of £640
- 25% of £640
- 75% of £640
- 20% of £640
- 15% of £640
- 32% of £640
- 8% of £640

Ibrahim earns £340 per week. He saves 15% of his wages. How many weeks will it take him to save £1000?

A shop has a 25% sale. A pair of trainers normally costs £84. Work out the discount. How much will I pay?

Topic 8: Multi-step Worded Questions inc Multiplying and Dividing with decimals

Column Multiplication

HTU x HTU

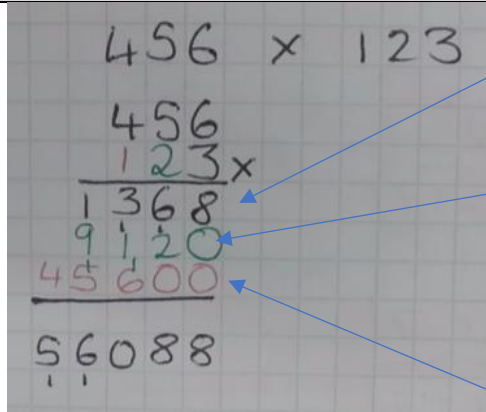

Multiply everything by the units

Insert a placeholder 0 before multiplying by the digit in the tens column

Insert two placeholder 00s before multiplying by the digit in the hundreds column

Add the three rows together

Multiplying with decimals

- Estimate answer mentally
- Count the digits after the decimal point in the question
- Do the sum without decimals
- Bounce the decimal point the number of times you counted from the right of the answer

$$3.77 \times 2.8 = ?$$

Estimate:

Least: $3 \times 2 = 6$

Most: $4 \times 3 = 12$

Answer between 6 and 12

$$\begin{array}{r} 3.77 \text{ (2 decimal places)} \\ \times 2.8 \text{ (1 decimal place)} \\ \hline 3016 \\ +7540 \\ \hline 10.556 \text{ (3 decimal places)} \end{array}$$

Division – remainders as fractions (mixed numbers)

- The whole number is how many whole groups you can make
- The remainder is the numerator
- The divisor is the denominator
- (Simplify where possible)

$17 \div 3 = 5r2$	$5\frac{2}{3}$
$20 \div 3 = 6r2$	$6\frac{2}{3}$
$20 \div 6 = 3r2$	$3\frac{2}{6} = 3\frac{1}{3}$ (Simplest form)
$4 \div 5 = 0r4$	$0\frac{4}{5} = \frac{4}{5}$

Short division

Carry remainders to the next number

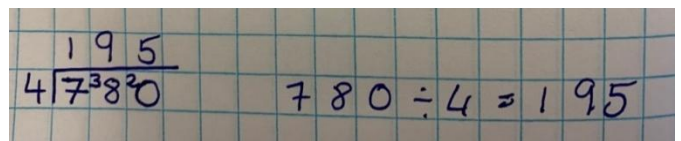

$7 \div 4 = 1r3$ then $38 \div 4 = 9r2$ then $20 \div 4 = 5$

If you run out of numbers, put a decimal and a zero

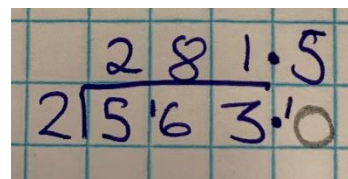

Decimals divided by integers (e.g. $9.24 \div 7$)

- Do the sum normally
- Align the decimal points inside and above the "bus stop"

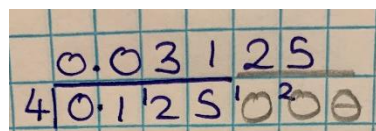

Try these multiplication questions

- 325×236
- 5.6×12.3
- 0.8×48.9
- $\text{£}14.59 \times 4$
- A parcel weighs 4.6kg. It costs $\text{£}3.20$ per kg to post it. How much will it cost to post the parcel.

Try these division questions

- $20 \div 6$ Give your answer as a mixed number
- $29 \div 2$ Give your answer as a decimal
- $129 \div 4$ Give your answer as a decimal
- $2093 \div 5$ Give your answer as a decimal
- $0.504 \div 3$
- $0.621 \div 4$

Topic 9: Coordinates, Lines, Reflections and Symmetries

Plotting and Reading Coordinates

Coordinates

A coordinate is written in brackets
(__, __)

The first number is the location on the x axis
The second number is the location on the y axis .
We always go along the corridor and up the stairs.

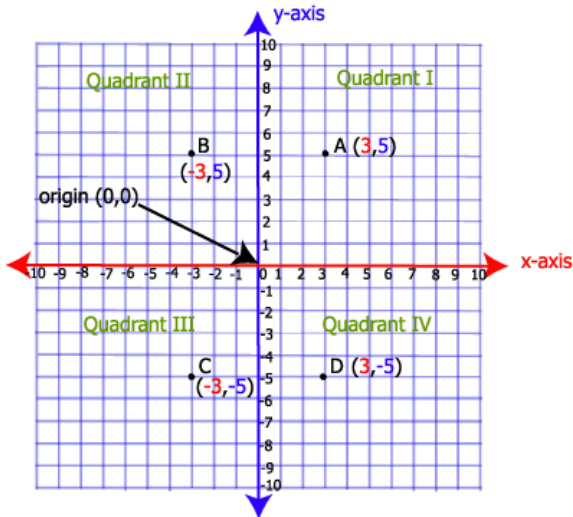

Plotting and Reading Lines

Recognizing graphs		
Line 1	$x = 3$	Horizontal lines always start $x =$
Line 2	$x = -2$	
Line 3	$y = -6$	Vertical lines always start $y =$
Line 4	$y = 2$	
Line 5	$y = x$	$Y = 1x (+0)$ Gradient is 1
Line 6	$Y = -x$	$Y = -1x (+0)$ Gradient is -1

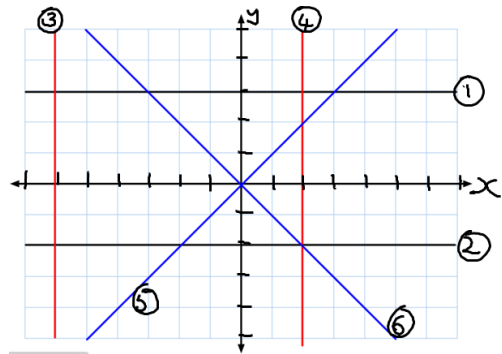

Reflections in lines

Example: Reflect shape A in the line $y = 2$

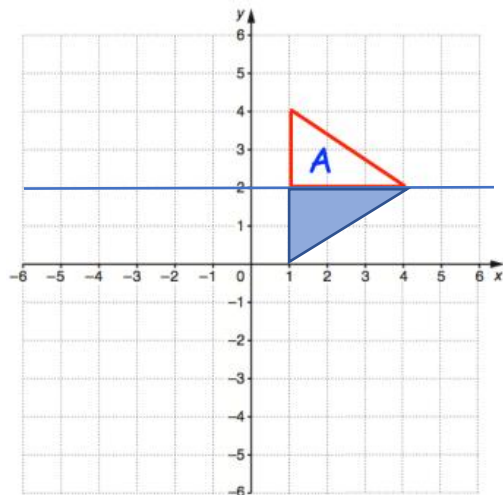

Note: in the above reflection, the vertices (1,2) and (4,2) are **invariant**. This means these points do not change.

Question to try: Reflect shape A in the line $x = 1$
Which vertices are invariant?

Midpoints of coordinates

To find the midpoints of coordinates add the x and y parts separately and divide each total by 2.

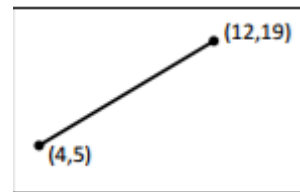

To find the midpoint
 $A = (4,5)$ and $B = (12, 19)$

X	Y
$\frac{4+12}{2} = 8$	$\frac{5+19}{2} = 12$
Midpoint is (8, 12)	

Questions: Find the midpoints of these coordinates
a) (4, 10) and (6, 12) b) (5, 2) and (10, 6)

Topic 10: Statistics

Types of average

There are three types of average: Mean, median and Mode

<u>Mean</u>	Add up all the numbers, then divide by how many numbers there are. Most useful when there are no outliers.	2, 7 and 9 Add : $2 + 7 + 9 = 18$ Divide: $18 \div 3 = 6$ So the Mean is 6
<u>Median</u>	The middle number (in a sorted list of numbers). Useful for when there are outliers or anomalies.	{13, 23, 11, 16, 15, 10, 26}. Order: {10, 11, 13, 15, 16, 23, 26} Cross off from both ends till you get to the middle: { 10 , 11 , 13, 15, 16, 23 , 26 } Median is 15.
<u>Mode</u>	The number which appears most often. Useful for non-numerical data (i.e. colours, animals)	In {6, 3, 9, 6, 6, 5, 9, 3} Mode is 6 (it occurs most often).

Range

The range is a measure of spread.

Large range means data is more spread out which means *less consistent*.

Small range means data is less spread out which means *more consistent*

In {4, 6, 9, 3, 7}
Lowest value is 3,
Highest is 9
Range is $9 - 3 = 6$.

Interpreting bar charts

Find the mode/range from a bar chart

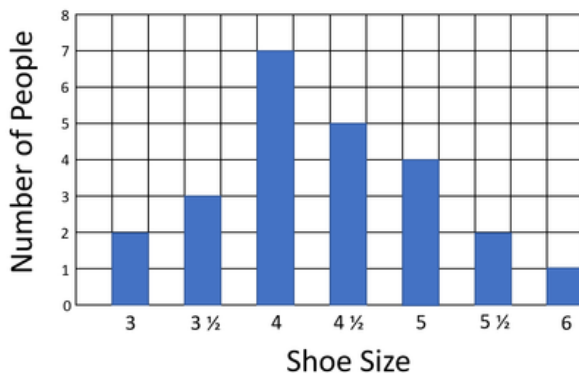

From the bar chart you can tell the **mode** (most frequent) is the shoe size **4** because it has the **tallest bar**. This means it has the **highest frequency**.

You can tell the largest shoe size is 6 and the smallest shoe size is 3 so the range is $6 - 3 = 3$ shoe sizes. All of the people are within three shoe sizes of each other. This means that the data is not very spread out.

Worded questions about data

Favourite Colour

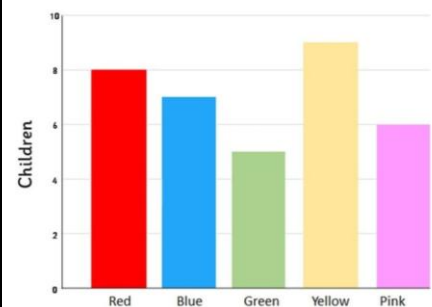

What proportion of children said their favourite colour is green. $\frac{\text{Green}}{\text{Total}} = \frac{5}{35}$

2) Here are some heights of a some pupils: 132cm, 129cm, 134cm, 138cm, 119cm.

What percentage of the pupils were taller than 130cm?

$$\frac{3}{5} \times \frac{20}{20} = \frac{60}{100} = 60\%$$

Questions to Try

1) Work out the mean, median, mode and range for these data sets

- 1, 5, 5, 7
- 6, 6, 10, 12, 26,
- 0, 6, 6, 13, 15, 20, 24
- 0.5, 0.1, 0.35, 0.405, 0.72

2) Dan asked 10 pupils how much pocket money they had. Here are the results

£10, £5, £0, £20, £5, £0, £5, £15, £50, £10

- What percentage of the pupils received no pocket money?
- What proportion received more than £10?
- Why would the mean be a bad average to use?

Topic 11 – Metric Units and Time	
<u>Metric Units of Mass</u>	<u>Metric Units of Capacity</u>
The prefix “Kilo” means 1000 (e.g. kilogram)	
a) Convert 5.6kg to grams b) Convert 0.8kg to grams c) Convert 875g to kilograms d) Convert 2300g to kilograms	a) Convert 4.05litres to millilitres b) Convert 0.4 litres to millilitres c) Convert 3400ml to litres d) Convert 475ml to litres
<u>Metric Units of Length</u>	<u>Units of Time</u>
The prefix “cent” means 100 (e.g. centimetre means 100 th of a metre)	AM means ante meridian (before noon) PM means post meridian (after noon)
	4:15pm = 16: 15 (add 12) 20:32 = 8:32pm (subtract 12)
a) Convert 8.5km to metres b) Convert 0.308km to metres c) Convert 450m to kilometres d) Convert 3750m to kilometres e) Convert 4m into centimetres f) Convert 0.6m into centimetres g) Convert 58cm into metres h) Convert 485cm into metres i) Convert 6.2cm into millimetres j) Convert 0.9cm into millimetres k) Convert 84mm into cm l) Convert 4mm into cm	An episode of a TV programme lasts for 85minutes. I start the episode at 8:30pm. What time does it finish? Give your answer in the 24hour format. A turkey takes 205 minutes to cook. I want to eat at 2:30pm. What time should I start to cook it at? Give your answer in the 24hour format.

Topic 12 Negative Numbers

Comparing and Ordering

> means greater than
< means less than

$$\begin{aligned} -8 < -4 \\ 5 > -11 \\ -2 > -3 \\ -1.8 < -1 \end{aligned}$$

Ascending means start with the smallest

Descending means start with the biggest

Addition and Subtraction

Write a vertical number line to help you solve these.

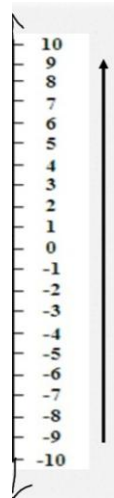

Multiplication and Division

When multiplying or dividing, pairs of the same sign will give a positive answer.

$$[+] \times [+] = [+] \quad 5 \times 6 = 30$$

$$[-] \times [-] = [+] \quad -5 \times -6 = 30$$

When multiplying or dividing, pairs of different signs will give a negative answer.

$$[+] \times [-] = [-] \quad 5 \times -6 = -30$$

$$[-] \times [+] = [-] \quad -5 \times 6 = -30$$

The same rules apply to division.

$$[+] \div [+] = [+] \quad 40 \div 5 = 8$$

$$[-] \div [-] = [+] \quad -40 \div -5 = 8$$

$$[+] \div [-] = [-] \quad 40 \div -5 = -8$$

$$[-] \div [+] = [-] \quad -40 \div 5 = -8$$

Compare using > < =

$$7 \underline{\quad} 1.4$$

$$-12 \underline{\quad} -10$$

$$2 \underline{\quad} -1$$

$$-3.8 \underline{\quad} -4$$

Put these in ascending order

-4, 3, -1, 0, -8, 5

Work out $5 - 12$

Work out $-8 - 12$

Work out $-7 + 2$

Work out $-2 + 6$

Work out $5 + -7$

Work out $-8 + -4$

Work out $8 - -1$

Work out $-10 - -4$

Work out 12×-5

Work out -3×8

Work out -7×-8

Work out $-4 \times -3 \times -5$

Work out $(-4)^2$

Work out $-20 \div 5$

Work out $-18 \div -3$

Work out $30 \div -5$

Topic 13 Indices, Roots and BIDMAS

Indices and Roots

Indices tell us how many times to multiply a number by itself

e.g. 5^3 means $5 \times 5 \times 5$

Evaluate means give the value so $5^3 = 125$

The command or verb "Square" means raise something to the power of 2, e.g. "Square 8" means $8^2 = 64$

The command or verb "Cube" means raise something to the power of 3, e.g. "Cube 2" means $2^3 = 8$

Square root is the opposite of square.

e.g. $\sqrt{64} = 8$

Cube root is the opposite of cube.

e.g. $\sqrt[3]{8} = 2$

We can write roots with indices like this:

$$\sqrt{64} = 8^{\frac{1}{2}} \quad \sqrt[3]{8} = 2^{\frac{1}{3}}$$

- Evaluate 4^2
- Evaluate 10^3
- What does 4^6 mean?
- Work out $\sqrt{144}$
- Work out $\sqrt[3]{64}$
- Find $25^{\frac{1}{2}}$
- Find $125^{\frac{1}{3}}$

BIDMAS

The order of operations is an agreed convention (rule)

- B Brackets
- I Indices
- DM Division and Multiplication
- AS Addition and Subtraction

$3 + 2 \times 5$	Multiplication before Addition. So $2 \times 5 = 10$ then $3 + 10 = 13$
$3 - 20 \div 5$	Division before Subtraction $20 \div 5 = 4$ then left to right to get $3 - 4 = -1$
$3 \times (2 + 5)$	We do the Group inside the bracket first ($2 + 5 = 7$) then multiply the result by 3. $3 \times 7 = 21$
$3 \times (2^2 + 5)$	Indices before Addition. $2^2 = 4$, add this to 5 then multiply the result by 3. $3 \times 4 + 5$ $3 \times 9 = 27$
$3 + 2 - 5$	Addition and Subtraction happen at the same time. Work left to right. $3 + 2 = 5$ $5 - 5 = 0$
$4 \times 30 \div 6$	Multiplication and Division happen at the same time. Work left to right. $4 \times 30 = 120$ $120 \div 6 = 20$

- Work out $5 + 4 \times 3$
- Work out $5 - 12 \div 3$
- Work out $(5 + 4^2) \times 3$
- Work out $(5 + 4)^2 \times 3$
- Work out $12 \times 4 \div 3$

Topic 14 Algebra Conventions, Substitution and Collecting

Term	Definition	Value when a = 4
a	1a (we don't write 1 in algebra)	4
3a	3 lots of 'a'	$3(4) = 12$
a + 3	3 more than 'a'	$(4) + 3 = 7$
a - 3	3 less than 'a'	$(4) - 3 = 1$
a ²	a x a a to the power 2	$(4)^2 = 16$
$\frac{a}{3}$	a' divided by 3 or "a third of a"	$\frac{4}{3}$ or $1\frac{1}{3}$

Collecting Like Terms:

"Letter, Number, Sign"

Collect like terms by

- Underline first letter
- Collect number and sign to the left
- Add or subtract

Continue until all like terms are collected together

$$3x + x \equiv 4x$$

$$2x + 1 + x + 2 \equiv 3x + 3$$

$$3x + 2 - x + 1 \equiv 2x + 3$$

$$2x + 6y + x - 2y \equiv 3x + 4y$$

$$3x - x \equiv 2x$$

$$2x + 3 - x - 8 \equiv x - 5$$

$$4x^2 + 3x - 2x + x^2 \equiv 5x^2 + x$$

Forming Expressions

Anna is "x" years old. Carl is 2 years older than Anna. Eddie is twice as old as Anna. Write a simplified expression for their total age.

Anna	Carl	Eddie	Total
x	x + 2	2x	x + x + 2 + 2x
			4x + 2

Anna is "x" years old. Carl is double Anna's age. Eddie is three years younger than Carl. Write a simplified expression for their total age.

Anna	Carl	Eddie	Total
x	2x	2x - 3	x + 2x + 2x - 3
			5x - 3

Try these questions

Write an expression that means...

- 6 more than x
- 6 less than x
- The sum of x and y
- The product of a and b
- a divided by b
- x multiplied by x
- Two lots of x

If a = 4, b = 5 and c = -3
Substitute into these expressions

- 2a
- 2c
- a + b
- 2b - 3b
- b² + c
- 3a²
- c²

Simplify the following by collecting like terms

- $4a + a + 3a \equiv$
- $5b + 2 - b + 6 \equiv$
- $y + 5 - y + 1 \equiv$
- $7x + x^2 - 2x + 4x^2 \equiv$

Topic 15 - Introducing Ratio

What is ratio?

Ratio is the relationship between two or more parts.

The ratio of boys to girls is 2:3. For every 2 boys, there are 3 girls.

Boys : Girls
2 : 3

Order matters

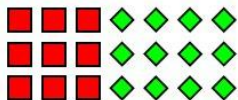

The ratio of diamonds to squares is 12:9

The fraction of shapes that are squares is $\frac{9}{21} = \frac{3}{7}$

Simplifying ratios

Must be in the same units. No units in the answer.
Divide both sides by a common factor

Squares : Diamonds

$\div 3$ $\begin{matrix} 9:12 \\ 3:4 \end{matrix}$ $\div 3$

Write 8km : 500m as a ratio in its simplest form

$\div 100$ $\begin{matrix} 8000 : 500 \\ 80:5 \end{matrix}$ $\div 5$ $\begin{matrix} 16:1 \end{matrix}$

Using "ratio tables"

i) Put the information into a RMA table.

	A	B	Total
R			
M			
A			

Amy and Barry share some money in the ratio 2:3.

Amy gets £12.

	A	B	Total
R	2	3	5
M	x6	X6	X6
A	12	18	30

ii) Work out the multiplier
 $12 \div 2 = 6$

iii) Work out any missing numbers

How much does Barry get? £18

iv) Answer the question

How much were they sharing in total? £30

Questions to try

i) Write the ratio of diamonds to squares in its simplest form

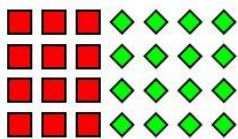

ii) Write 4500m to 3km as a ratio in its simplest form
iii) Write £5.60 to 80p as a ratio in its simplest form

i) Andy and Bryn are sharing sweets in the ratio 3:5
Andy gets 60 sweets.

How many sweets does Bryn get?

How many were they sharing in total?

How many more sweets does Bryn get compared to Andy?

ii) $x:y = 4:7$ $Y = 28$

Work out $x + y$

Work out $y - x$

Work out $x - y$

Topic 16: Forming and Solving Equations

Solving one-step equations

$x + 6 = 20$ -6 -6 $x = 14$	$x - 6 = 20$ +6 +6 $x = 26$
$5x = 10$ $\div 5 \div 5$ $x = 2$	$10x = 5$ $\div 10 \div 10$ $x = \frac{5}{10}$ or 0.5
$\frac{x}{5} = 20$ $x5 \ x5$ $x = 100$	$\frac{1}{5}x = 20$ $x5 \ x5$ $x = 100$

Solving two-step equations

$2x + 6 = 20$ -6 -6 $2x = 14$ $\div 2 \div 2$ $x = 7$	$3x - 5 = 22$ +5 +5 $3x = 27$ $\div 3 \div 3$ $x = 9$
$\frac{x}{4} - 3 = 17$ +3 +3 $\frac{x}{4} = 20$ $x4 \ x4$ $x = 80$	$10x + 18 = 10$ -18 -18 $10x = -8$ $\div 10 \div 10$ $x = \frac{-8}{10}$ or -0.8

Try these questions

Solve $x + 4 = 25$	Solve $3x = 18$	Solve $2x + 1 = 21$	Solve $\frac{x}{10} - 2 = 18$
Solve $x - 7 = 19$	Solve $6x = -30$	Solve $2x - 1 = 21$	
Solve $x + 3.5 = 16$	Solve $18x = 3$	Solve $3x - 5 = 12$	Solve $8 = \frac{x}{2} + 12$
Solve $x + 15 = 5$	Solve $\frac{x}{4} = 16$	Give answer as a mixed number	
Solve $x - 2 = -20$	Solve $\frac{1}{3}x = 12$	Solve $4x + 10 = 2$	Solve $\frac{1}{3}x + 2 = 18 + 5$

Topic 17: Angles

Classifying and labelling angles

Example

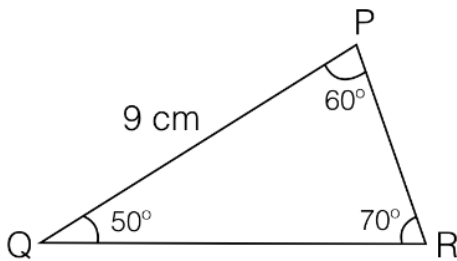

A line is labelled with two letters
Example: Line QP is 9cm

An angle is labelled with three letters.
Example: Angle PRQ is 70°

Questions:

Write down the size of angle QPR
Write down the size of angle PQR

Classifying Types of angle

Acute	Right	Obtuse	Reflex
Less than 90°	90°	More than 90° and less than 180°	More than 180° and less than 360°

Angle facts

Fact	Question
Angles on a straight line that share a point	
Angles around a point	
Vertically opposite angles	
Angles in a triangle	

Questions to try

Draw an angle of 45°

Draw an angle of 135°

What do you notice if you put your angles together?

What type of angle is

- 190°
- 23°
- 100°

Not drawn accurately.

Work out the size of angle y .
State the fact you used.

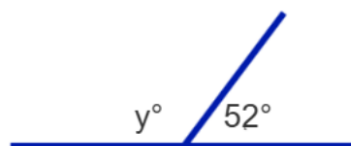

Not drawn accurately.

Work out the size of angle y .
State the fact you used.

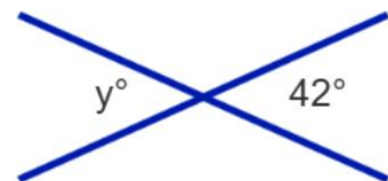

Not drawn accurately.

Work out the size of angle y .
State the fact you used.

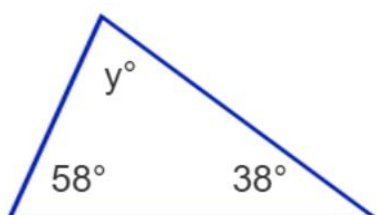

Not drawn accurately.

Work out the size of angle y .
State the fact you used.

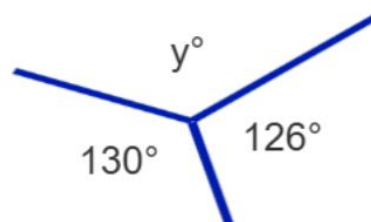

Not drawn accurately.

Work out the size of angle y .
State the fact you used.

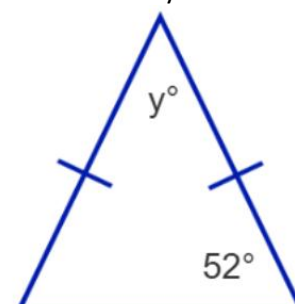

Topic 18: Area

Area

Area is the **space inside** a 2D shape. It is measured in square units such as mm^2 , cm^2 , m^2 , and km^2 .

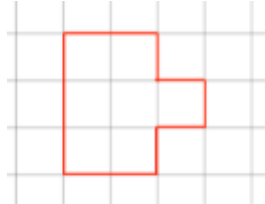

Area of this shape is 7cm^2

Area of squares and rectangles

A **Square** has four equal sides

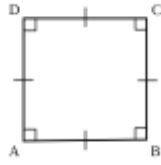

Area = Length x Length
or
Area = Length²

A **Rectangle** has 2 pairs of equal opposite sides

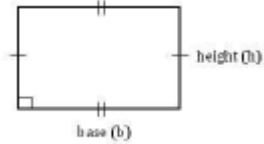

Area = Base x Height

Area of parallelograms

A **Parallelogram** has 2 pairs of equal opposite sides

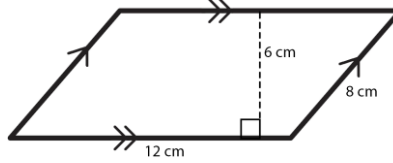

The **perpendicular height** is at a right angle to the base.

Area = base x perpendicular height

In example above

Area = $12 \times 6 = 72\text{cm}^2$

Area of triangles

A **Triangle** has three sides.

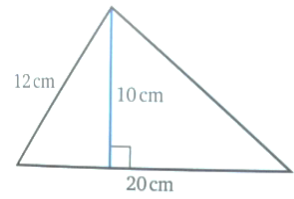

The **perpendicular height** is at a right angle to the base.

Area =

$\frac{\text{base} \times \text{perpendicular height}}{2}$

In example above

Area = $\frac{20 \times 10}{2} = 100\text{cm}^2$

Questions to try

Work out the area of these shapes

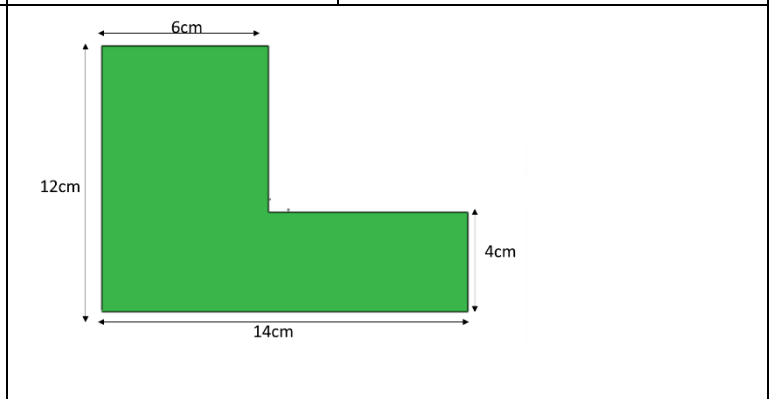
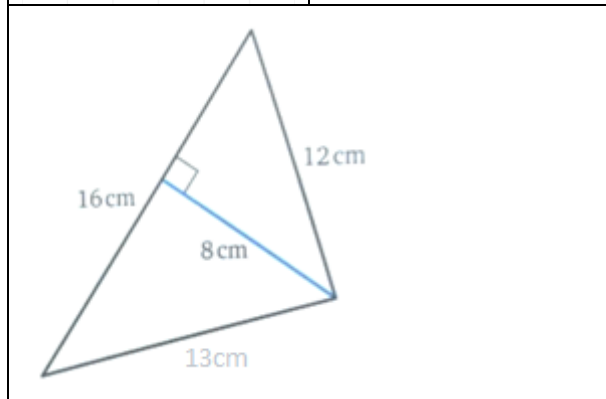
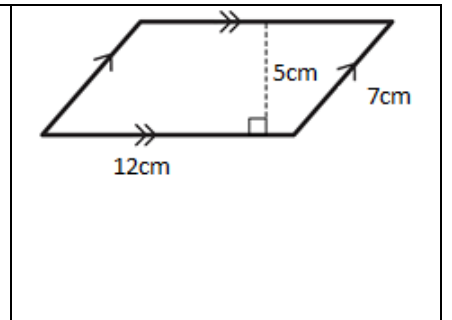
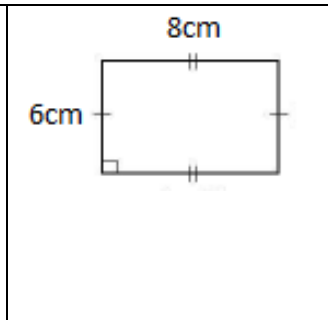
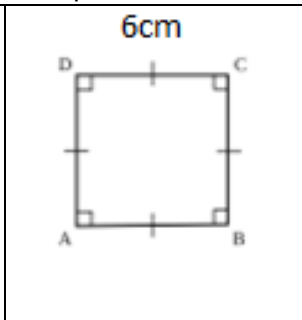
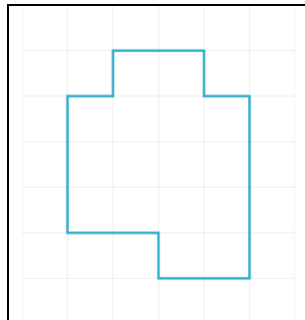

Topic 19: Sequences

Types of sequence

Square number	The result of multiplying an integer by itself. 2×2 can be written as $2^2 = 4$ 3×3 can be written as $3^2 = 9$	The square number sequence starts 1, 4, 9, 16, 25, 36, ...
Cube number	The result of multiplying an integer by itself and then multiplying by itself again. $2 \times 2 \times 2$ can be written as $2^3 = 8$ $3 \times 3 \times 3$ can be written as $3^3 = 27$	The cube number sequence starts 1, 8, 27, 64, 125, ...
Triangular number	A number that when represented as dots can be arranged in the shape of a triangle . The gap between the numbers in the sequence grows by 1 each time.	1, 3, 6, 10, 15, ... +2 +3 +4 +5 +6
Arithmetic or Linear Sequence	sequence which goes up or down in equal steps .	Examples: 4, 7, 10, 13 (Rule is +3) or 15, 10, 5, 0 (Rule is -5) or 5, 7.5, 10, 12.5 (Rule is +2.5)
Geometric Sequence	sequence which is created by multiplying by the same number each time. Note- multiplying by a fraction is same as dividing.	Example: 3, 12, 48, 192 (Rule is $\times 4$) Example: 20, 10, 5, 2.5 (Rule is $\times 0.5$)
Fibonacci Sequence	is generated by adding the two previous terms	Example: 1, 1, 2, 3, 5, 8, 13

Learn these sequences using the learn, cover, write technique.

Questions

- 1) What is the third square number?
- 2) What is the fourth cube number?
- 3) What is the fifth triangular number?
- 4) Is 9, 13, 20 an arithmetic sequence? Explain your answer
- 5) Continue the sequence that starts 5, 15,... in two different ways

Generating Sequences

[Term-to-term rule](#)

a rule that tells you how to get to the **next term in a sequence**

Example: the term-to-term rule is multiply by 2 then add 6. The first term is 4. Generate the first three terms of the sequence

$$4 \qquad 14 \qquad 34$$

$$\times 2 + 6 \qquad \times 2 + 6$$

[Position-to-term rule \(nth term rule\)](#)

a rule that tells you how to find any number in a sequence

Example: the position-to-term rule for a sequence is $4n - 1$

Use this rule to generate the first five terms of the sequence

Substitute the values $n=1, 2, 3, 4, 5$.

$$4(1) - 1 = 4 - 1 = 3$$

$$4(2) - 1 = 8 - 1 = 7$$

$$4(3) - 1 = 12 - 1 = 11$$

$$4(4) - 1 = 16 - 1 = 15$$

$$4(5) - 1 = 20 - 1 = 19$$

3, 7, 11, 15, 19

Questions

- 1) The first term in a sequence is 8, the term to term rule is subtract 3. Write down the first five terms of the sequence
- 2) The position-to-term rule of a sequence is $3n + 4$. Generate the first five terms of the sequence